

PRESSURE STABILIZATION IN A HYDRAULIC PRESS

V. V. Evdokimova, A. D. Novikov,
and V. K. Naumov

UDC 539.893

This article describes a unit which consists of a scouring valve and a system of automatic pumping of the oil, which maintains a constant pressure in the cylinder of a laboratory press for a prolonged period.

The described pressure stabilization system was used on several types of laboratory presses which develop forces of up to 300, 500, 6000, and 10,000 tons and restricted the pressure fluctuations in the press cylinder to a value not exceeding 1 to 1.5 atm. Two alternating actions are made the basis of the stabilization process: slow scouring of the oil excesses from the press cylinder through a valve, and periodic pumping-up of the oil in the cylinder to the initial stipulated pressure. The press feed system with pressure stabilization is shown in Fig. 1. It consists of a feed channel (a hydraulic pump 1, a receiver 2), a scouring channel (the valve 3), and an electronic attachment 4 which operates as a pair with a contact transducer which is mounted in the sample manometer 5. One of the transducer contacts is the tip of the sample-manometer pointer (this contact is first coated with silver), while the second contact sets the magnitude of the pressure and is isolated from the manometer casing (for example, it may be attached to a slider which moves freely along the generant of the manometer casing). Depending on the operating conditions, either the lower or upper value of the working pressure may be chosen as the limiting

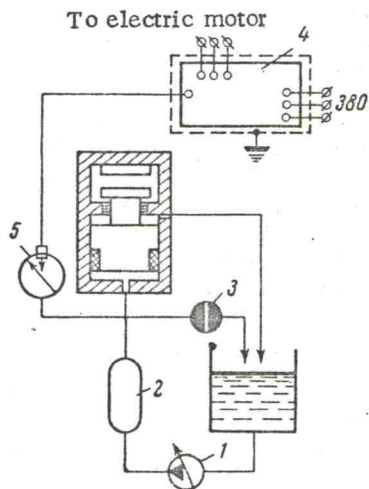

Fig. 1

Fig. 1. Diagram of the hydraulic-press feed. 1) Hydraulic pump; 2) receiver; 3) scouring valve; 4) electronic attachment; 5) sample manometer with contact pressure transducer.

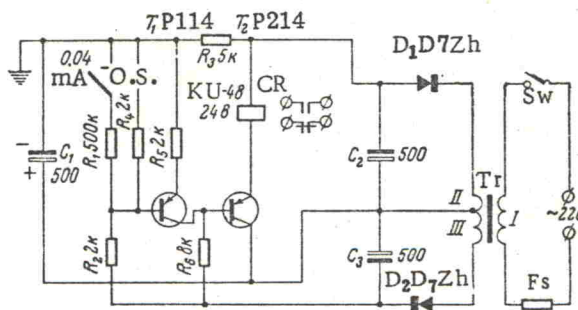

Fig. 2

Fig. 2. Schematic of the electronic attachment.

Institute of High-Pressure Physics, Academy of Sciences of the USSR. Translated from *Pribory i Tekhnika Éksperimenta*, No. 2, pp. 244-245, March-April, 1971. Original article submitted July 10, 1970.

©1971 Consultants Bureau, a division of Plenum Publishing Corporation, 227 West 17th Street, New York, N. Y. 10011. All rights reserved. This article cannot be reproduced for any purpose whatsoever without permission of the publisher. A copy of this article is available from the publisher for \$15.00.